



JAD™
shell & coil
heat exchangers

>>> effective heat transfer >>>



JAD shell & coil heat exchanger consists of shell and a spiral coil inside. Compact construction, high efficiency in comparison to standard solutions, easy installation and reliability are the core advantages of JAD. It is manufactured using stainless steel and comes in numerous size versions.

In JAD X connections are set in the shape of a letter X which lowers pressure loss at high flow velocity. It also reduces fouling and makes the exchanger more resistant to differences in media parameters. JAD X can be entirely emptied using gravitation and comes in many versions able to handle wide range of temperatures, pressures and flows. In K versions corrugated tubes promote turbulent fluid flow which further intensifies heat exchange and helps the reduction of deposits.

JAD can be successfully used in standard installations and district heating substations, whereas JAD X is ideal for installations with increased temperature and pressure requirements, e.g. steam applications or oil coolers.

Core advantages:

- compact size with large heat exchange area
- space saving thanks to vertical installation
- high efficiency – unique design promotes greater turbulence
- able to handle wide range of temperatures, pressures, flows and media

CONSTRUCTION

JAD heat exchangers are counter current flow devices. Heat exchange area is built by layers of helicoidal coaxial counter coiled tubes of diameter Ø 8mm or Ø 10mm. Coil is ended on both sides with tubesheets placed in head's connections. Other two connections are used to connect the exchanger to the installation. Heat exchanger is a welded unit build of high-alloy austenitic stainless steel. In K versions corrugated tubes increase flow turbulence which further intensifies heat exchange.

MATERIALS

- stainless steel
- flanges: stainless steel (SS) or carbon steel (CS)

MEDIA

- water
- steam
- glycol

MATERIAL TYPE

- STA - shell 304L / 1.4307
- tubes 321 / 1.4541
- PRO - 316L / 1.4404

APPLICATION

- heating systems
- heating substations
- HVAC installations
- heat exchange in industrial processes
- chemical and food industry

WORKING PARAMETERS

	tubes		shell	
	temp.	pressure	temp.	pressure
EE	165°C	1,6 MPa	165°C	1,6 MPa
FF	200°C	1,6 MPa	200°C	1,6 MPa
MF	250°C	2,5 MPa	200°C	1,6 MPa
BF	200°C	3,5 MPa	200°C	1,6 MPa
S	165°C	1,6 MPa	165°C	1,6 MPa
SX	200°C	1,6 MPa	200°C	1,6 MPa
H	200°C	1,6 MPa	200°C	1,6 MPa



TECHNICAL PARAMETERS

Type	Heat exchange area m ²	Tube diameter mm	Weight* kg	Tube side capacity l	Shell side capacity l	Dimensions [mm]						Type and material of connections	Connection size
						A	B	C	D	Dz	alfa		
JAD (K) 3.18	2,2	8	25,7	4,8	5,0	114	1260	1604	-	102	-	flange CS ; flange SS	DN32, DN40
JAD (K) 5.36	3,6	8	39,6	7,8	9,5	132	1220	1604	-	140	-	flange CS ; flange SS	DN40, DN65
JAD (K) 6.50	5,7	8	51,6	11,4	12,8	136	1220	1604	-	159	-	flange CS ; flange SS	DN50, DN65
JAD (K) 6.50.10	4,8	10	48,0	10,8	13,4	136	1220	1604	-	159	-	flange CS ; flange SS	DN50, DN65
JAD (K) 14.163	24,7	8	192,0	39,4	48,6	220	1467	2238	-	324	-	flange CS ; flange SS	DN100, DN150
JAD (K) 14.163.10	18,2	10	165,8	47,4	50,0	220	1467	2238	-	324	-	flange CS ; flange SS	DN100, DN150
JAD (K) 15.177.10	35,5	10	350	81,1	128,8	340	1235	2640	-	406	-	flange CS ; flange SS	DN200, DN150
JAD (K) 15.177.10.75	16,5	10	215	51,8	65,0	340	485	1890	-	406	-	flange CS ; flange SS	DN200, DN150
JAD (K) 15.177.10.100	22,5	10	268	65,5	91,0	340	735	2140	-	406	-	flange CS ; flange SS	DN200, DN150
JAD (K) 26.480	77,4	8	661	154,7	145,3	560	1460	2890	-	508	-	flange CS ; flange SS	DN250, DN200
JAD X(K) 2.11	1,2	8	19,6	2,3	2,6	160	1513	1625	253	80	100	flange CS ; flange SS, WD	DN40, OD 48,3 mm
JAD X(K) 2.11.08.68	0,6	8	14,5	1,2	1,2	160	835	942	253	80	100	flange CS ; flange SS, WD	DN40, OD 48,3 mm
JAD X(K) 3.18	2,0	8	27,1	4,0	5,0	172	1510	1634	278	102	100	flange CS ; flange SS, WD	DN50, OD 60,3 mm
JAD X(K) 3.18.08.75	1,2	8	21,1	2,6	2,5	172	917	1041	278	102	100	flange CS ; flange SS, WD	DN50, OD 60,3 mm
JAD X(K) 5.38	4,0	8	42,4	6,6	11,2	201	1510	1649	317	140	100	flange CS ; flange SS, WD	DN65, OD 76,1 mm
JAD X(K) 5.38.08.71	2,3	8	30,5	4,0	6,8	201	908	1047	317	140	100	flange CS ; flange SS, WD	DN65, OD 76,1 mm
JAD X(K) 6.50	5,3	8	51,9	11,2	13,6	206	1492	1653	341	159	100	flange CS ; flange SS, WD	DN80, OD 88,9 mm
JAD X(K) 6.50.08.72	3,1	8	37,3	4,6	9,9	206	907	1068	341	159	100	flange CS ; flange SS, WD	DN80, OD 88,9 mm
JAD X(K) 6.50.10	5,1	10	50,9	14,2	10,6	206	1492	1653	341	159	100	flange CS ; flange SS, WD	DN80, OD 88,9 mm
JAD X(K) 9.88	10,7	8	84,2	16,0	29,0	253	1481	1676	416	219	100	flange CS ; flange SS, WD	DN100, OD 114,3 mm
JAD X(K) 9.88.08.65	4,9	8	52,1	6,6	20,8	253	886	1050	416	219	100	flange CS ; flange SS, WD	DN100, OD 114,3 mm
JAD X(K) 9.88.08.85	6,2	8	60,1	8,2	25,0	253	1086	1250	416	219	100	flange CS ; flange SS, WD	DN100, OD 114,3 mm
JAD X(K) 9.88.10	8,3	10	76,2	13,0	32,0	253	1481	1676	416	219	100	flange CS ; flange SS, WD	DN100, OD 114,3 mm
JAD X(K) 12.114	18,4	8	140,2	20,1	54,2	344	1681	1883	484	273	110	flange CS ; flange SS, WD	DN125, OD 139,7mm
JAD X(K) 12.114.08.50	6,3	8	71,2	8,0	29,0	344	781	983	484	273	110	flange CS ; flange SS, WD	DN125, OD 139,7mm
JAD X(K) 12.114.08.60	6,5	8	73,8	9,0	34,0	344	881	1083	484	273	110	flange CS ; flange SS, WD	DN125, OD 139,7mm
JAD X(K) 12.114.08.75	8,8	8	86,6	10,0	38,5	344	1031	1233	484	273	110	flange CS ; flange SS, WD	DN125, OD 139,7mm
JAD X(K) 12.114.10	14,9	10	127,7	19,3	55,0	344	1681	1883	484	273	110	flange CS ; flange SS, WD	DN125, OD 139,7mm
JAD X(K) 17.217	58,4	8	487,5	85,1	240,0	670	1855	2364	-	508	36	flange CS ; flange SS, WD	DN150, OD 159,0 mm
JAD X(K) 17.217.10	39,0	10	454,1	77,6	239,0	670	1855	2364	-	508	36	flange CS ; flange SS, WD	DN150, OD 159,0 mm
S 0 X(K)	2,3	8	19,0	3,3	6,2	204	911	1026	300	140	100	flange CS ; flange SS	DN40
S 1 X(K)	3,1	8	22,0	4,5	9,8	206	993	1108	302	159	100	flange CS ; flange SS	DN40
S1 (K)	3,0	8	31,1	6,2	8,1	160	700	1060	-	159	-	flange CS ; flange SS	DN40, DN50
H0 K	0,3	8	7,1	0,5	1,0	100	418	585	-	80	-	external thread, flange SS	G ½"/G ¾", DN15/DN20
H1 K	0,8	8	10,3	1,1	2,4	110	618	800	-	102	-	external thread, flange SS	G ½"/G ¾", DN15/DN20
H2 K	1,3	8	13,4	1,9	3,0	110	890	1060	-	102	-	external thread, flange SS	G 1"/G 1", DN25/DN25

*weight for FF version with flanges

SS- stainless steel, CS - carbon steel, WD - connection to be welded

TECHNICAL DRAWING

Standard location of connections (in counterflow):

- K1/K4 – inlet/outlet hot side
- K3/K2 – inlet/outlet cold side
- K5 – hot water circulation (optional)

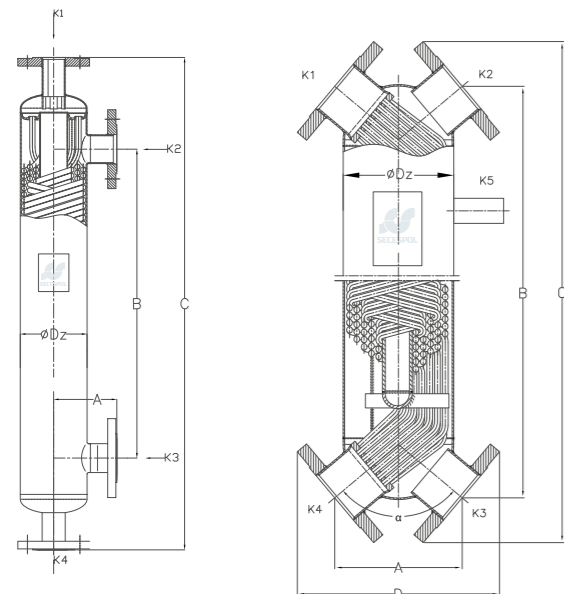

INSULATION

Insulation for JAD heat exchanger is easy to install and dismantle. It is made of polyurethane foam (PFI) or aluminium covered mineral wool (AMWI). Insulation consists of two parts fastened with bands (PFI) or latch clamps (AMWI).

Working parameters:

- max. working temperature: +135 °C (for PFI); +250 °C (for AMWI)
- thickness: 30 mm (for PFI); 80mm (for AMWI)
- thermal conductivity: 0,024 W/mK (for PFI); 0,035 W/mK (for AMWI)





www.secespol.com