

- Vacuum resistance with elastomer diaphragms:  $10^{-3}$  mbar  
Helium tightness (leak rate):  $10^{-6}$  atm.cm<sup>3</sup>/s
- Vacuum resistance with PTFE diaphragms:  $10^{-3}$  mbar  
Helium tightness (leak rate):  $10^{-3}$  atm.cm<sup>3</sup>/s
- Fatigue strength: Min. 100000 operations with elastomer diaphragms  
40000 operations with PTFE diaphragms.

#### EEC CONFORMITY

Our valves comply with European regulations (EEC) within the limits of use described in paragraph B.

CE mark on the valve indicates the conformity to the following regulations :



- **2014/30/EU** "Electromagnetic compatibility"
- **2014/68/EU** "Pressurized equipment"
- **2014/35/EU** "Low pressure"
- **2006/42/EC** "Machines"

#### B- Use limits

Use pressure has to be lower than 10 bars for all products.

In case of dangerous gas (1) valve diameter (line) must be below 100 mm.

For use outside these limits, please contact our technical service.

(1) dangerous gas : group 1 gas , identified by a letter on the label and on the security card of the product :

E (for detonating gas), O (for fuel), F+, F and R10 (inflammable), T+ and T (toxic).

For additional information, please see regulation **1272/2008** "Labelling of dangerous products".

#### SPARE PARTS AND ACCESSORIES

Note the date of manufacture on the bottom body (1) and refer to the general documentation or consult us.

Please consult us in the event of a malfunction.

Note: All users of DEFINOX valves must periodically check the condition of the installed equipment, in particular of parts playing a "safety" role (checking interval to be set according to the use and the cleaning applied)



## FITTING INSTRUCTIONS

### DMX DIAPHRAGM VALVE

[www.definox.com](http://www.definox.com)

DEFINOX SAS

3 Rue des Papetiers - Z.A.C. de Tabari 2

44190 Clisson - France

☎ : +33 (0)2 28 03 98 50

📠 : +33 (0)2 28 03 88 00

E-mail : [info@definox.com](mailto:info@definox.com)

## DMX MANUAL DIAPHRAGM VALVE

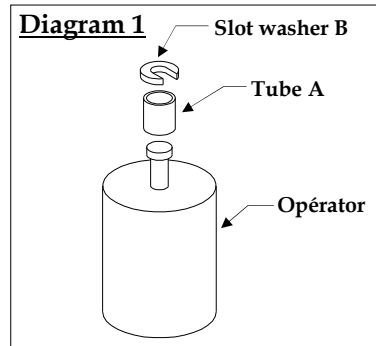
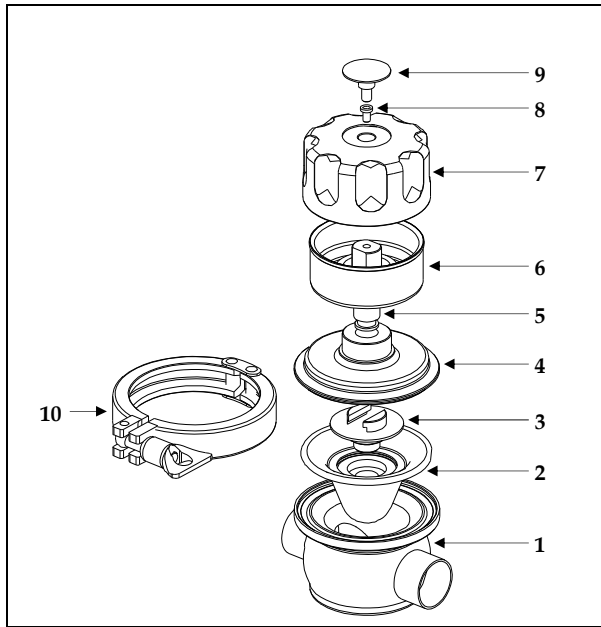

## DMAX AUTOMATIC DIAPHRAGM VALVE

- 1 : Bottom body
- 2 : Diaphragm
- 3 : Connecting screw
- 4 : Top body
- 5 : Control screw
- 6 : Casing
- 7 : Handle
- 8 : Retaining screw
- 9 : Diaphragm cover index
- 10 : Clamp
- 11 : Operator assembly

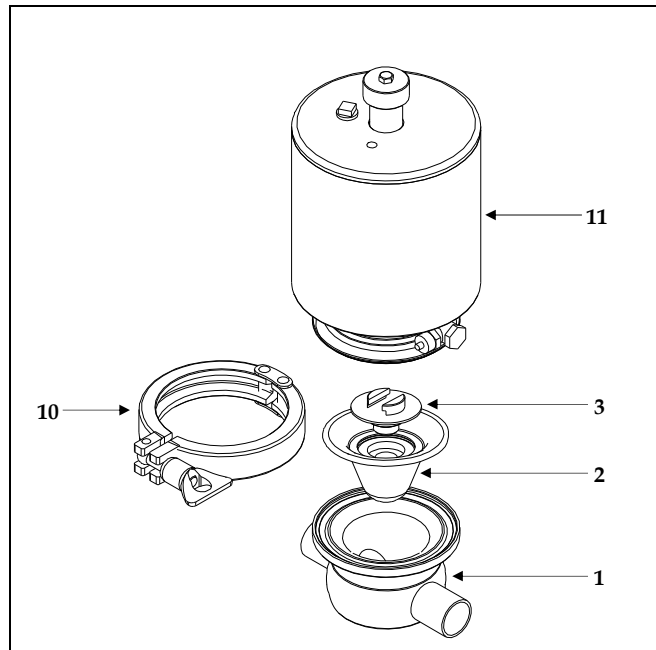

Follow the fitting and operating instructions carefully. Take account of the actual working conditions and comply with the valve specifications indicated in the DEFINOX catalogue.

### VALVE IDENTIFICATION

The DEFINOX diaphragm valve has an identification number under the lower body (1). This information will be useful later to identify any spare parts you may require.

### POSSIBLE DIAPHRAGM TYPES

The following types of diaphragm can be mounted on your valve:

PTFE

EPDM

SILICONE

Please contact our Technical Department to define the type of diaphragm suited to your process.

### DIAPHRAGM VALVE INSTALLATION

Store your valve in its original packaging to prevent damage. Disassemble the valve before welding it to your process line. Turn the handle to bring the valve to the "start opening" position or supply air to the operator (11) to add the tube and slot washer B then release the air (see Diagram 1). Remove the clamp (10). Cut the air supply and remove the operator assembly (11) or manual operator assembly (4-5-6-7-8-9), the diaphragm (2) and the connecting screw (3) from the bottom body (1). Connect the bottom body (1) to your process line.

### FITTING DIAPHRAGM VALVES

Centre the diaphragm assembly (2-3) on the manual operator assembly (4-5-6-7-8-9) or automatic operator (11) before inserting them into the bottom body (1) (check that the markers on part 4, diaphragm 2 and body 1 are aligned) Check that the handle is in the "start opening" position or that the operator is fastened with the tube A and slot washer B in the "start opening" position (if not, proceed as described above). Position and tighten the clamp (10). When using for the first time, check the connections and the joint between the bottom body (1) and the top body (4) for leaks (or the lantern on the automatic valve).

**N.B.** During sawing operations, avoid getting chips or filings in the pipes and rinse the pipes thoroughly with the valve open to avoid damaging the seals when the valve is put into service.

### WORKING CONDITIONS

The actuator is supplied with dry, filtered air at a pressure of 4.5 bar (minimum) to 8 bar (maximum). The operator air couplings are designed for a 4/6 diameter hose fitting (6/8 on large models). The working fluid pressure is 10 bar with elastomer diaphragms at 20°C and 8 bar with PTFE diaphragms at 20°C. The valve accepts a maximum temperature of 140°C (0°C minimum temperature with PTFE diaphragms).

.../...