

8) REFITTING DCX3 DE VALVES

Ensure that the seal bearing surface inside body (1) is clean. Check the position of seal (3) on the operator lantern. Put the valve into the “ open ” position. For an N.C. configuration, supply air to the operator and fit the shut-off assembly (2) in the body, making sure the seals are not damaged around the part edges. Refit the half clamps (5) and screws (4). When using for the first time, check the top and bottom connections for leaks.

NOTE:

- We recommend the use of a **medium threadlocker** to lock the piston during its reassembly to the automatic actuator.
- During sawing operations, avoid getting chips or filings in the pipes and rinse the pipes thoroughly with the valve open to avoid damaging the seals when the valve is put into service.

9) STORAGE

We recommend that our valves are stored away from site pollution (abrasive dust, shocks, acid or chlorinated products, U.V., etc.) for as long as possible and are assembled, where possible, to avoid mixing up of components.

10) SPARE PARTS AND OPERATOR DISASSEMBLY

We can provide you with the component references for your valve on request. You can also make a note of the valve identification number.

Actuator disassembly is a simple but delicate operation requiring the use of the appropriate tools and reference to the valve disassembly instructions.

Please contact us for these instructions or to request maintenance operations at our premises or on site.

N.B.: The valve must be out of service prior to any intervention and disassembly of the components with the pretensioned spring must be performed in accordance with the instructions on the maintenance information sheet.

All users of DEFINOX valves must periodically check the condition of the installed equipment, in particular of parts playing a “safety” role (checking interval to be set according to the use and the cleaning applied)

11) EEC CONFORMITY

A - Our valves comply with European regulations (EEC) within the limits of use described in paragraph B.

The CE mark on the valve indicates conformity to the following regulations :



- **2014/30/EU** "Electromagnetic compatibility"
- **2014/68/EU** "Pressurized equipment"
- **2014/35/EU** "Low pressure"
- **2006/42/EC** "Machines"

B - Use limits :

Usage pressure must be lower than 10 bar for all products.

In case of dangerous gas⁽¹⁾ valve diameter (line) must be below 100 mm.

For use outside these limits, please contact our technical service.

⁽¹⁾dangerous gas : group 1 gas, identified by a letter on the label and on the security card of the product :

E (for detonating gas), O (for fuel), F+, F and R10 (inflammable), T+ and T (toxic).

For additional information, please see regulation **1272/2008** "Labeling of dangerous products".



INSTALLATION GUIDE

DCX3 DUAL SEAL CHANGEOVER VALVE

www.definox.com

DEFINOX SAS

3 Rue des Papetiers - Z.A.C. de Tabari 2

44190 Clisson - France

☎ : +33 (0)2 28 03 98 50

📠 : +33 (0)2 28 03 88 00

E-mail: info@definox.com

DCX3 DUAL SEAL AUTOMATIC VALVE

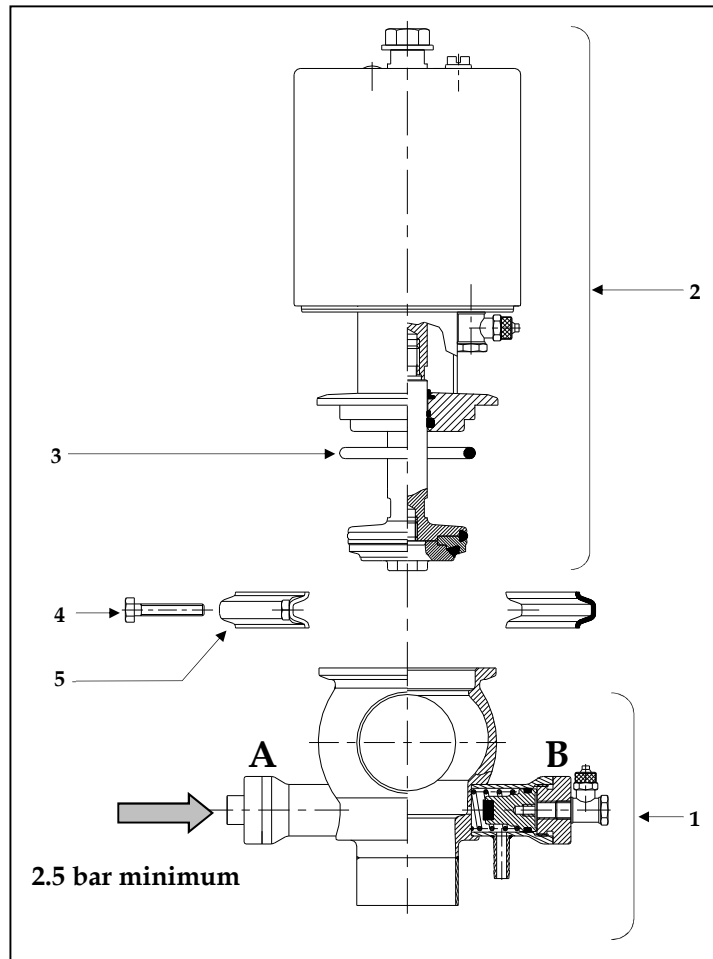

- 1 : DCX3 body + cleaning and leak assembly (cleaning inspection port optional).
2 : Plug sub-assembly
3 : Seal
4 : Clamp (2 x ½ clamps)
5 : Clamp screw
A : Cleaning inlet on leak chamber.
B : Leakage indicator

IMPORTANT : To change the actuator configuration, please refer to the disassembly instructions or contact our Technical Department.

For trouble-free installation of your DEFINOX DCX3 DE. seal, we recommend that you read these instructions which describe the main steps required to put your valve into service and include useful advice :

1) VALVE IDENTIFICATION

DEFINOX changeover valves have an identification number. You will need this number in order to identify the spare parts you may request.

2) SERVICE CONDITIONS

The working conditions of this valve (pressure, temperature, fluid transported, etc.) must comply with the general technical specifications described in the DEFINOX catalogue available on request. If you have any questions, please contact us.

3) AIR SUPPLY CONDITIONS

The actuator is supplied with dry, filtered air at a pressure of 4.5 to 8 bar. The operator air couplings are designed for a 4/6 diameter hose fitting. The valve has a max. working pressure of 6 bar, a max. temperature of 120°C and an acceptable vacuum of 0.3 bar.

4) SEALS

Unless otherwise specified in the order, DCX3 DE valves are equipped with the following seals :

- Food grade Viton for O-rings

Other types are also available :

- EPDM
- Silicone
- Acid-resistant Viton

Choosing the right type of seal is very important for correct valve operation. This is not always easy as the characteristics of the fluids circulating through the valve must all be taken into consideration. We are available to provide you with assistance. Ensure that the grease used is compatible with elastomere seals, particularly EPDM.

5) NC ASSEMBLY (normally closed) – N.O (normally open)– D.A. (dual action).

DCX3 DE valves are supplied as standard in an N.C. configuration (normally closed) and require an air supply to remove the plug.

We can supply in configuration N.O (normally open) or D.A. (double acting) on request.

Important : Before changing the configuration, consult the maintenance instructions for the DCX3 DE valve.

6) INSTALLING THE VALVE ON THE PROCESS LINE

To install the valve on the process line, **the weld-on body must be separated** from the rest of the valve to prevent seal damage.

To carry out this simple operation, proceed as follows while referring to the diagrams :

Put the valve in the “ open ” position. With an N.C. configuration, the operator (2) must be supplied with air. Remove the clamp (5) by loosening the screws (4). Shut off the air and separate the body (1) from the rest of the valve. Weld the body to the pipes. Never block or reduce the leak chamber.

7) PRECAUTIONS TO BE TAKEN WHEN CARRYING OUT WELDING OF THE BODIES

Adjust the pipes : check the straightness, the out-of-roundness and the offset (play<0.5 mm), to limit the restrictions created by welding.

Any modification to the valve body for the purpose of welding must be carried out with the agreement of Definox.

Support the pipes by at least 10D of the valve (nominal diameter of valve).

.../...